

Notice for TAIYO YUDEN products

Please read this notice before using the TAIYO YUDEN products.

REMINDERS

- Product information in this catalog is as of October 2009. All of the contents specified herein are subject to change without notice due to technical improvements, etc. Therefore, please check for the latest information carefully before practical application or usage of the Products.

Please note that Taiyo Yuden Co., Ltd. shall not be responsible for any defects in products or equipment incorporating such products, which are caused under the conditions other than those specified in this catalog or individual specification.

- Please contact Taiyo Yuden Co., Ltd. for further details of product specifications as the individual specification is available.
- Please conduct validation and verification of products in actual condition of mounting and operating environment before commercial shipment of the equipment.

- All electronic components or functional modules listed in this catalog are developed, designed and intended for use in general electronics equipment.(for AV, office automation, household, office supply, information service, telecommunications, (such as mobile phone or PC) etc.). Before incorporating the components or devices into any equipment in the field such as transportation,(automotive control, train control, ship control), transportation signal, disaster prevention, medical, public information network (telephone exchange, base station) etc. which may have direct influence to harm or injure a human body, please contact Taiyo Yuden Co., Ltd. for more detail in advance. Do not incorporate the products into any equipment in fields such as aerospace, aviation, nuclear control, submarine system, military, etc. where higher safety and reliability are especially required.

In addition, even electronic components or functional modules that are used for the general electronic equipment, if the equipment or the electric circuit require high safety or reliability function or performances, a sufficient reliability evaluation check for safety shall be performed before commercial shipment and moreover, due consideration to install a protective circuit is strongly recommended at customer's design stage.

- The contents of this catalog are applicable to the products which are purchased from our sales offices or distributors (so called "TAIYO YUDEN' s official sales channel"). It is only applicable to the products purchased from any of TAIYO YUDEN' s official sales channel.

- Please note that Taiyo Yuden Co., Ltd. shall have no responsibility for any controversies or disputes that may occur in connection with a third party's intellectual property rights and other related rights arising from your usage of products in this catalog. Taiyo Yuden Co., Ltd. grants no license for such rights.

- Caution for export

Certain items in this catalog may require specific procedures for export according to "Foreign Exchange and Foreign Trade Control Law" of Japan, "U.S. Export Administration Regulations", and other applicable regulations. Should you have any question or inquiry on this matter, please contact our sales staff. Should you have any question or inquiry on this matter, please contact our sales staff.

WOUND TORROIDS AND BEADS



WAVE

FEATURES

- Use of high loss ferrite materials for excellent high frequency noise absorption.
- High impedance for normal mode applications.
- 05 RD type available in taping for automatic insertion.
- 06 BT type is designed for high current applications (3A).

APPLICATIONS

- Absorption of high frequency noise from digital equipment data lines.

OPERATING TEMP.

- -25°C~105°C (Including self-generated heat)

ORDERING CODE

[FL-R / RD Type]

F L 0 5 R D 2 0 0 A T ○

1 Type	2 Dimensions of core	3 Shape	4 Nominal inductance (μH)	5 Inductance tolerance	6 Packaging	7 Internal code
FL Wound torroids and beads	05 4.8mm	R△ Ring core, with single wire lead RD Ring core, with case, pin type △=Blank space	example 1R0 1.0 200 20.0 *R=decimal point	A Higher than normal value E Special tolerance	△ Bulk T Tape & Reel Z Ammo - Special code △=Blank space	△ Standard product 07 Product classification code △=Blank space

[FL-BT Type]

F L 0 6 B T 0 4 ○

1 Type	2 Dimensions of core (diameter)	3 Shape	4 Product classification code	5 Internal code
FL Wound torroids and beads	06 6.0mm	BT Cylinder, porous core	04	△ Standard product △=Blank space

EXTERNAL DIMENSIONS/MINIMUM QUANTITY

Type	[05RD]	[05R]	[06BT04]
Fig.			
Minimum Quantity (pcs.)	Bulk 400 Tape & Reel 2000 Ammo 1500	Bulk 500 Tape & Reel - Ammo -	Bulk 250 Tape & Reel - Ammo -

Unit : mm (inch)

IMPEDANCE-FREQUENCY CHARACTERISTICS

Measured by HP4291A

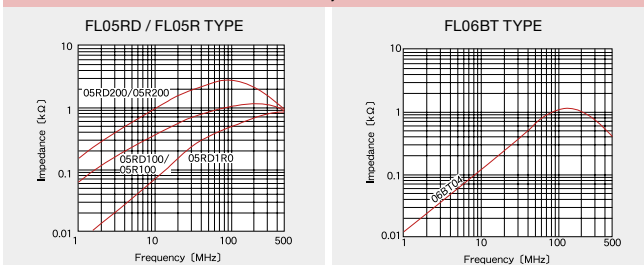

Please contact TAIYO YUDEN for further information in regard to other characteristics.

* This catalog contains the typical specification only due to the limitation of space. When you consider purchase of our products, please check our specification. For details of each product (characteristics graph, reliability information, precautions for use, and so on), see our Web site (<http://www.ty-top.com/>) or CD catalogs.

■ PART NUMBERS

Ordering code		EHS (Environmental Hazardous Substances)	Inductance [μ H]	Impedance [Ω] (typical)	DC Resistance [Ω] (max)	Rated current [A] (max)
FL05RD 1R0E□		RoHS	1.0 ^{+1.0} _{-0.5}	800 (at 400MHz)	0.08	0.5
FL05R 100A		RoHS	10 min.	900 (at 200MHz)	0.05	1.5
FL05RD 100A□		RoHS				
FL05R 200A-07		RoHS	20 min.	2000 (at 100MHz)	0.08	
FL05RD 200A□		RoHS				
FL06BT 04		RoHS	—	1000 (at 150MHz)	0.05	3.0

□ Please specify the packaging code (T : Tape & reel, Z : ammo, Blank space : bulk)

* This catalog contains the typical specification only due to the limitation of space. When you consider purchase of our products, please check our specification. For details of each product (characteristics graph, reliability information, precautions for use, and so on), see our Web site (<http://www.ty-top.com/>) or CD catalogs.

PACKAGING

① Minimum Quantity

Type	Minimum Quantity (pcs.)		
	Bulk	Tape & Reel	Ammo
FL05R	500	—	—
FL05RD	400	2000	1500
FL06BT	250	—	—

② Taping dimensions

● FL05RD

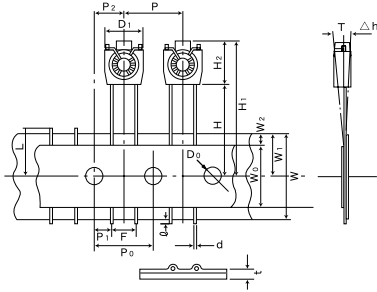

Type	Symbol	Dimension
FL05RD	D ₁	9.0 max. (0.354 max.)
	H ₂	9.0 max. (0.354 max.)
	T	3.7 max. (0.146 max.)
	H ₁	31.0 max. (1.22 max.)
	H	18.0±1.0 (0.709±0.039)
	P	12.7±1.0 (0.500±0.039)
	P ₀	12.7±0.3 (0.500±0.012) ※1
	P ₁	3.85±0.8 (0.152±0.031)
	P ₂	6.35±1.3 (0.250±0.051)
	W ₁	9.0 ^{+0.75} _{-0.5} (0.354 ^{+0.030} _{-0.020})
	F	5.0 ^{+0.6} _{-0.2} (0.197 ^{+0.024} _{-0.008})
	d	φ0.6 (φ0.024)
	Δh	0±2.0 (0±0.079)
	W	18.0 ^{+1.0} _{-0.5} (0.709 ^{+0.024} _{-0.008})
	W ₀	12.5 min. (0.492 min.)
	W ₂	3.0 min. (0.118 min.) ※2
	ℓ	0 max. (0 max.)
	D ₀	4.0±0.3 (0.157±0.012)
L	11.0 max. (0.433 max.)	
t	0.7±0.2 (0.028±0.008)	

※1 Accumulated error for 20 pitches shall be within ±2mm. Unit : mm (inch)
 ※2 Pasting tape shall not exceed paste board.

③ Reel size

● FL05RD

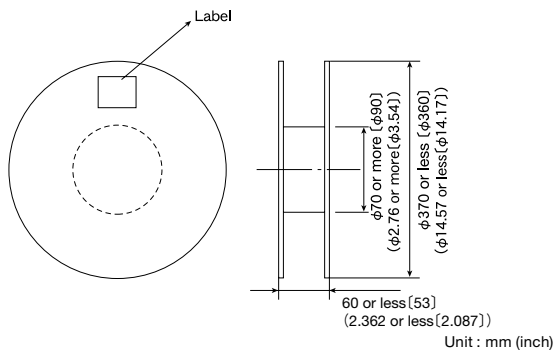

Dimensions in parenthesis are measured value.

* This catalog contains the typical specification only due to the limitation of space. When you consider purchase of our products, please check our specification. For details of each product (characteristics graph, reliability information, precautions for use, and so on), see our Web site (<http://www.ty-top.com/>) or CD catalogs.

RELIABILITY DATA

1. Operating temperature Range	
LA Type	-25~+105°C
CAL45 Type	
LHL□□□	
FBA/FBR	-25~+85°C
FL05□ Type	-25~+105°C
FL06BT Type	

[Test Method and Remarks]
 LA·CA·FL : Including self-generated heat
 LHL□□□ : Including self-generated heat

2. Storage temperature Range	
LA Type	-40~+85°C
CAL45 Type	
LHL□□□	
FBA/FBR	
FL05□ Type	
FL06BT Type	

3. Rated current	
LA Type	Within the specified tolerance
CAL45 Type	
LHL□□□	
FBA/FBR	
FL05□ Type	
FL06BT Type	

[Test Method and Remarks]
 LA, CA : The maximum DC value having inductance within 10% and temperature increase within 40°C (LA:20°C) by the application of DC bias.
 LHL□□□ : The maximum DC value having inductance decrease within 10% (LHLC08, LHLC10 : within 30%) and temperature increase within the following specified temperature by the application of DC bias.
 Reference temperature : 25°C (LHL08, LHL10, LHL13)
 : 30°C (LHL16, LHLP□□)
 : 40°C (LHLC08, LHLC10)
 FB : No disconnection or appearance abnormality by continuous current application for 30 min. Change after the application shall be within ±20% of the initial value.
 This is not guaranteed for electrical characteristics during current application.
 FL : The maximum DC value having temperature rise within specified value.

4. Impedance	
LA Type	Within the specified tolerance
CAL45 Type	
LHL□□□	
FBA/FBR	
FL05□ Type	
FL06BT Type	

[Test Method and Remarks]
 FB : Measuring equipment : Impedance analyzer (HP4191A) or its equivalent
 Measuring frequency : Specified frequency
 FL06BT : Measuring equipment : 4291A (HP) or its equivalent
 Measuring frequency : Specified frequency

5. Inductance	
LA Type	Within the specified tolerance
CAL45 Type	
LHL□□□	
FBA/FBR	
FL05□ Type	
FL06BT Type	

[Test Method and Remarks]
 LA, CA : Measuring equipment : LCR meter (HP4285A + HP42851A or its equivalent)
 Measuring frequency : Specified frequency
 LHL□□□ : Measuring equipment : LCR meter (HP4285A+HP42851A or its equivalent)
 LCR meter (HP4263A) or its equivalent (at 1kHz)
 Measuring frequency : Specified frequency
 FL05R□ : Measuring equipment : HP4262A or its equivalent
 Measuring frequency : 1kHz

6. Q	
LA Type	Within the specified tolerance
CAL45 Type	
LHL□□□	
FBA/FBR	
FL05□ Type	
FL06BT Type	

[Test Method and Remarks]
 LA : Measuring equipment : LCR meter (HP4285A + HP42851A or its equivalent)
 Measuring frequency : Specified frequency
 LHL□□□ (except LHLP) : Measuring equipment : LCR meter (HP4285A+HP42851A or its equivalent)
 LCR meter (HP4263A) or its equivalent (at 1kHz)
 Measuring frequency : Specified frequency

* This catalog contains the typical specification only due to the limitation of space. When you consider purchase of our products, please check our specification.
 For details of each product (characteristics graph, reliability information, precautions for use, and so on), see our Web site (<http://www.ty-top.com/>) or CD catalogs.

RELIABILITY DATA

7. DC Resisittance

LA Type	Within the specified tolerance
CAL45 Type	
LHL□□□	
FBA/FBR	
FL05□ Type	
FL06BT Type	

[Test Method and Remarks]

LA, CA : Measuring equipment : low ohmmeter (A&D AD5812 or its equivalent)
 LHL□□□・FB・FL : Measuring equipment : DC ohmmeter

8. Self resonance frequency

LA Type	Within the specified tolerance
CAL45 Type	
LHL□□□	
FBA/FBR	
FL05□ Type	
FL06BT Type	

[Test Method and Remarks]

LA : Measuring equipment : Network analyzer (Anritsu MS620J or its equivalent)
 LHL□□□ (except LHLP) : Measuring equipment : (HP4191A, 4192A) its equivalent

9. Temperature characteristic

LA Type	△L/L : Within ±5%
CAL45 Type	
LHL□□□	△L/L : Within ±7% (except LHLP16 : Within ±20%)
FBA/FBR	
FL05□ Type	
FL06BT Type	

[Test Method and Remarks]

LA : Change of maximum inductance deviation in step 1 to 5

Step	Temperature (°C)
1	20
2	-25 (Minimum operating temperature)
3	20 (Standard temperature)
4	+85 (Maximum operating temperature)
5	20

LHL□□□ : Change of maximum inductance deviation in step 1 to 5

Temperature at step 1 : 20°C
 Temperature at step 2 : Minimum operating temperature
 Temperature at step 3 : 20°C (Standard temperature)
 Temperature at step 4 : Maximum operating temperature
 Temperature at step 5 : 20°C

10. Terminal strength : tensile force

LA Type	No abnormality such as cut lead, or looseness.
CAL45 Type	
LHL□□□	
FBA/FBR	
FL05□ Type	
FL06BT Type	

[Test Method and Remarks]

LA : Apply the stated tensile force progressively in the direction to draw terminal.

force (N)	duration (s)
25	5

CA : Apply the stated tensile force progressively in the direction to draw terminal.

force (N)	duration (s)
10	10

LHL□□□ : Apply the stated tensile force progressively in the direction to draw terminal.

Nominal wire diameter tensile ϕd (mm)	force (N)	duration (s)
$0.3 < \phi d \leq 0.5$	5	30±5
$0.5 < \phi d \leq 0.8$	10	
$0.8 < \phi d \leq 1.2$	25	

FBA/FBR : A bead shall be fixed and static loaded $20 \pm 1N$ (2.0 ± 0.1 kgf) in axial direction of lead wire in 10 ± 1 seconds.

FL05R□ : Fix the component in the direction to draw terminal, and gradually apply the tensile force of 4.9N.

11. Over current

LA Type	No emission of smoke no firing.
CAL45 Type	
LHL□□□	There shall be no scorch or short of wire. LHLC08, LHLC10 : There shall be no firing.
FBA/FBR	
FL05□ Type	
FL06BT Type	

[Test Method and Remarks]

LHL□□□/LA・CAL45 Type : Measuring current : Rated current×2
 Duration : 5 min.
 Number of measuring : one time

RELIABILITY DATA

12. Terminal strength : bending	
LA Type	No abnormality such as cut lead, or looseness.
CAL45 Type	
LHL□□□	
FBA/FBR	
FL05□ Type	
FL06BT Type	

[Test Method and Remarks]

LA, CA : Suspend a mass at the end the terminal, incline the body though angel of 90 and return it to initial position. This operation is done over a period of 2-3 sec. Then second bend in the opposite direction shall be made.
Number of bends : Two times.

Nominal wire diameter tensile ϕd (mm)	Bending force (N)	Mass reference weight (kg)
$0.5 < \phi d \leq 0.8$	5	0.50

LH·FB : Suspend a mass at the end the terminal, incline the body though angel of 90 and return it to initial position. This operation is done over a period of 2-3 sec. Then second bend in the opposite direction shall be made.
Number of bends : Two times.

Nominal wire diameter tensile ϕd (mm)	Bending force (N)	Mass reference weight (kg)
$0.3 < \phi d \leq 0.5$	2.5	0.25
$0.5 < \phi d \leq 0.8$	5	0.5
$0.8 < \phi d \leq 1.2$	10	1.0

13. Insulation resisance : between the terminals and body	
LA Type	100M Ω min.
CAL45 Type	
LHL□□□	
FBA/FBR	
FL05□ Type	
FL06BT Type	

[Test Method and Remarks]

LHL□□□ : Applied voltage : 500 VDC
Duration : 60 sec.

14. Insulation resistance : between terminals and core	
LA Type	1M Ω min. (Other than materail code MA)
CAL45 Type	
LHL□□□	
FBA/FBR	
FL05□ Type	
FL06BT Type	

[Test Method and Remarks]

FBA·FBR : Applied voltage : 100 VDC
Duration : 60±5 sec.

15. Withstanding : between the terminals and body	
LA Type	No abnormality such as insulation damage
CAL45 Type	
LHL□□□	
FBA/FBR	
FL05□ Type	
FL06BT Type	

[Test Method and Remarks]

LHL□□□ : Accoding to JIS C5102. 7. 1. 3 (C)
Metal global method
Applied voltage : 500 VDC
Duration : 60 sec.

16. DC bias characteristic	
LA Type	$\Delta L/L$: Within -10%
CAL45 Type	
LHL□□□	
FBA/FBR	
FL05□ Type	
FL06BT Type	

[Test Method and Remarks]

LA, CA : Measure inductance with appliation of rated current using LCR meter to compare it with the initial value.

17. Body strength	
LA Type	No abnormality as damage.
CAL45 Type	
LHL□□□	No abnormality such as cracks on body.
FBA/FBR	
FL05□ Type	
FL06BT Type	

[Test Method and Remarks]

LA : Applied force : 30N
Duration : 10 sec.
Speed : Shall attain to specified force in 2 sec.

CAL45 : Applied force : 50N
Duration : 10 sec.
Speed : Shall attain to specified force in 2 sec.

FBA : Applied force : 50±3N
Duration : 30±1 sec.

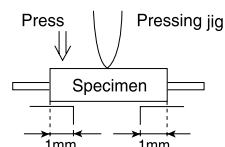

* This catalog contains the typical specification only due to the limitation of space. When you consider purchase of our products, please check our specification.
For details of each product (characteristics graph, reliability information, precautions for use, and so on), see our Web site (<http://www.ty-top.com/>) or CD catalogs.

RELIABILITY DATA

18. Resitance to vibration	
LA Type	$\Delta L/L$: Within $\pm 5\%$ Q : 30min
CAL45 Type	$\Delta L/L$: Within $\pm 5\%$
LHL□□□	Appearance : No abnormality $\Delta L/L$: Within $\pm 5\%$ Q change : Within $\pm 30\%$ (LHLP : only $\Delta L/L$)
FBA/FBR	Appearance : No abnormality Impedance change : Within $\pm 20\%$
FL05□ Type	
FL06BT Type	
[Test Method and Remarks]	
LA, CA	: Directions : 2 hrs each in X, Y and Z directions total : 6hrs. Frequency range : 10 to 55 to 10Hz (1min.) Amplitude : 1.5mm Mounting method : Soldering onto printed board. Recovery : At least 1hr of recovery under the standard condition after the test, followed by the measurement within 2hrs.
LHL□□□·FB	: Directions : 2 hrs each in X, Y and Z directions total : 6hrs. Frequency range : 10 to 55 to 10Hz (1min.) Amplitude : 1.5mm (But don't exceed acceleration 196m/s^2 (two power)) Mounting method : Soldering onto printed board.
19. Resistance to shock	
LA Type	No significant abnormality in appearance
CAL45 Type	
LHL□□□	
FBA/FBR	
FL05□ Type	
FL06BT Type	
[Test Method and Remarks]	
LA, CA	: Drop test Impact material : concrete or vinyl tile Height : 1m Total number of drops : 10 times
20. Solderability	
LA Type	At least 75% of terminal electrode is covered by new solder.
CAL45 Type	At least 75% of terminal electrode is covered by new solder.
LHL□□□	At least 75% of terminal electrode is covered by new solder.
FBA/FBR	At least 90% of terminal electrode is covered by new solder.
FL05□ Type	At least 75% of terminal electrode is covered by new solder.
FL06BT Type	At least 75% of terminal electrode is covered by new solder.
[Test Method and Remarks]	
LA, CA	: Solder temperature : $230\pm 5^\circ\text{C}$ Duration : 2 ± 0.5 sec.
LHL□□□	: Solder temperature : $235\pm 5^\circ\text{C}$ Duration : 2 ± 0.5 sec. Immersion depth : Up to 1.5mm from bottom of case.
FB	: Solder temperature : $230\pm 5^\circ\text{C}$ Duration : 3 ± 1 sec. Immersion depth : Up to 1.5mm from terminal root.
FL05R□	: Solder temperature : $230\pm 5^\circ\text{C}$ Duration : 2 ± 0.5 sec. Immersion depth : Up to 2 to 2.5mm from terminal root.
FL06BT	: Solder temperature : $230\pm 5^\circ\text{C}$ Duration : 3 ± 1 sec. Immersion depth : Up to 0.5 to 1.0mm from terminal root.
21. Resitance to soldering heat	
LA Type	No significant abnormality in appearance
CAL45 Type	$\Delta L/L$: Within $\pm 5\%$
LHL□□□	No significant abnormality in appearance Inductance change : Within $\pm 5\%$ Q change : Within $\pm 30\%$ (LHLP : only $\Delta L/L$)
FBA/FBR	No significant abnormality in appearance Impedance change : Within $\pm 20\%$
FL05□ Type	Refer to individual specification
FL06BT Type	No significant abnormality in appearance Impedance change : Within $\pm 20\%$
[Test Method and Remarks]	
LA, CA	: Solder temperature : (CA) $270\pm 5^\circ\text{C}$, (LA) $260\pm 5^\circ\text{C}$ Duration : 5 ± 0.5 sec. One time Immersed conditions : Inserted into substrate with $t=1.6\text{mm}$ Recovery : At least 1hr of recovery under the standard condition after the test, followed by the measurement within 2hrs.
LHL□□□	: Solder bath method : Solder temperature : $260\pm 5^\circ\text{C}$ Duration : 10 ± 1 sec. Up to 1.5mm from bottom of case. Manual soldering : Solder temperature : $350\pm 10^\circ\text{C}$ (At the tip of soldering iron) Duration : 5 ± 1 sec. Up to 1.5mm from bottom of case. Caution : No excessive pressing shall be applied to terminald. Recovery : 4 to 24hrs of recovery under the standard condition after the test.
FB	: Solder bath method : Condition 1 : Solder temperature : $260\pm 5^\circ\text{C}$ Duration : 10 ± 1 sec. Immersion depth : Up to 1.5mm from terminal root. Condition 2 : Solder temperature : $350\pm 5^\circ\text{C}$ Duration : 3 ± 1 sec. Immersion depth : Up to 1.5mm from terminal root. Recovery : 3hrs of recovery under the standard condition after the test.
FL	: Solder condition : $260\pm 5^\circ\text{C}$ 10 ± 1 sec. Immersion depth : Up to 0.5 to 1.0mm from terminal root. Recovery : 3hrs of recovery under the standard condition after the test.

* This catalog contains the typical specification only due to the limitation of space. When you consider purchase of our products, please check our specification.
For details of each product (characteristics graph, reliability information, precautions for use, and so on), see our Web site (<http://www.ty-top.com/>) or CD catalogs.

RELIABILITY DATA

22. Resisistance to solvent	
LA Type	Please avoid the ultrasonic cleaning of this product.
CAL45 Type	
LHL□□□	
FBA/FBR	No significant abnormality in appearance Impedance change : Within ±20%
FL05□ Type	
FL06BT Type	

[Test Method and Remarks]

FB : Solvent temperature : 20~25°C
 Duration : 30±5 sec.
 Solvent type : Acetone, trichloroethylene
 Recovery : 3hrs of recovery under the standard condition after the test.

23. Thermal shock	
LA Type	△L/L : Within ±10% Q : 30min
CAL45 Type	△L/L : Within ±10%
LHL□□□	Appearance : No abnormality Inductance change : Within ±10% Q change : Within ±30% (LHLP : only △L/L)
FBA/FBR	Appearance : No abnormality Impedance change : Within ±20%
FL05□ Type	Refer to individual specification
FL06BT Type	Appearance : No abnormality Impedance change : Within ±20%

[Test Method and Remarks]

LA, CA : Conditions for 1cycle

Step	Temperature (°C)	Duration (min.)
1	-25 ⁺⁰ ₋₃	30±3
2	Room temperature	Within 3
3	+85 ⁺² ₋₀	30±3
4	Room temperature	Within 3

Number of cycles : 5 cycles
 Recovery : At least 1hr of recovery under the standard condition after the removal from test chamber, followed by the measurement within 2hrs.

LHL□□□·FB : Accoding to JIS C0025

Conditions for 1 cycle

Step	Temperature (°C)	Duration (min.)
1	Minimum operating temperature ⁺⁰ ₋₃	30±3
2	Room temperature	Within 3
3	Minimum operating temperature ⁺² ₋₀	30±3
4	Room temperature	Within 3

Number of cycles : 10 cycles (LHL□□□)
 : 5 cycles (FBA, FBR)
 Recovery : 4 to 24hrs of recovery under the standard condition after the removal from the test chamber. (LHL□□□)
 : 3hrs of recovery under the standard condition after the removal from the test chamber. (FBA, FBR)

FL : Accoding to JIS C0025

Conditions for 1 cycle

Step	Temperature (°C)	Duration (min.)
1	-25 ⁺⁰ ₋₃	30±3
2	Room temperature	Within 3
3	+85 ⁺² ₋₀	30±3
4	Room temperature	Within 3

Number of cycles : 10 cycles
 Recovery : 1 to 2hrs of recovery under the standard condition after the removal from the test chamber.

24. Damp heat	
LA Type	△L/L : Within ±10% Q : 30min
CAL45 Type	△L/L : Within ±10%
LHL□□□	
FBA/FBR	Appearance : No abnormality Impedance change : Within ±20%
FL05□ Type	
FL06BT Type	

[Test Method and Remarks]

LA, CA : Temperature : 40±2°C
 Humidity : 90~95%RH
 Duration : 1000 hrs
 Recovery : At least 1hr of recovery under the standard removal from test chamber, followed by the measurement within 2hrs.

FB : Temperature : 60±2°C
 Humidity : 90~95%RH
 Duration : 1000 hrs
 Recovery : 1 to 2hrs of recovery under the standard condition after the removal from the test chamber.

* This catalog contains the typical specification only due to the limitation of space. When you consider purchase of our products, please check our specification. For details of each product (characteristics graph, reliability information, precautions for use, and so on), see our Web site (<http://www.ty-top.com/>) or CD catalogs.

RELIABILITY DATA

25. Loading under damp heat	
LA Type	$\Delta L/L$: Within $\pm 10\%$ Q : $\pm 30\text{min}$
CAL45 Type	$\Delta L/L$: Within $\pm 10\%$
LHL□□□	Appearance : No abnormality Inductance change : Within $\pm 10\%$ Q change : Within $\pm 30\%$ (LHLP : only $\Delta L/L$)
FBA/FBR	
FL05□ Type	Refer to individual specification
FL06BT Type	Appearance : No abnormality Impedance change : Within $\pm 20\%$
[Test Method and Remarks]	
LA, CA	: Temperature : $40\pm 2^\circ\text{C}$ Humidity : $90\sim 95\%\text{RH}$ Duration : 1000 hrs Applied current : Rated current Recovery : At least 1hr of recovery under the standard removal from test chamber, followed by the measurement within 2hrs.
LHL□□□	: Temperature : $40\pm 2^\circ\text{C}$ Humidity : $90\sim 95\%\text{RH}$ Duration : 1000 ± 24 hrs Applied current : Rated current Recovery : 1 to 2hrs of recovery under the standard condition after the removal from the test chamber.
FL	: Temperature : $60\pm 3^\circ\text{C}$ Humidity : $90\sim 95\%\text{RH}$ Duration : 500 (+12, -0) hrs Applied current : Rated current Recovery : 1 to 2hrs of recovery under the standard condition after the removal from the test chamber.
26. Loading at high temperature	
LA Type	$\Delta L/L$: Within $\pm 10\%$ Q : $\pm 30\text{min}$
CAL45 Type	$\Delta L/L$: Within $\pm 10\%$
LHL□□□	
FBA/FBR	
FL05□ Type	
FL06BT Type	
[Test Method and Remarks]	
LA, CA	: Temperature : $85\pm 2^\circ\text{C}$ Duration : 1000 hrs Applied current : Rated current Recovery : At least 1hr of recovery under the standard removal from test chamber, followed by the measurement within 2hrs.
27. Low temperature life test	
LA Type	$\Delta L/L$: Within $\pm 10\%$ Q : $\pm 30\text{min}$
CAL45 Type	$\Delta L/L$: Within $\pm 10\%$
LHL□□□	Appearance : No abnormality Inductance change : Within $\pm 10\%$ Q change : Within $\pm 30\%$ (LHLP : only $\Delta L/L$)
FBA/FBR	
FL05□ Type	Refer to individual specification
FL06BT Type	Appearance : No abnormality Impedance change : Within $\pm 20\%$
[Test Method and Remarks]	
LA, CA	: Temperature : $-25\pm 2^\circ\text{C}$ Duration : 1000 hrs Recovery : At least 1hr of recovery under the standard removal from test chamber, followed by the measurement within 2hrs.
LHL□□□	: Temperature : $-40\pm 3^\circ\text{C}$ Duration : 1000 ± 24 hrs Recovery : 1 to 2hrs of recovery under the standard condition after the removal from the test chamber.
FL	: Temperature : $-40\pm 3^\circ\text{C}$ Duration : 500 (+12, -0) hrs Recovery : 1 to 2hrs of recovery under the standard condition after the removal from the test chamber.
28. High temperature life test	
LA Type	
CAL45 Type	
LHL□□□	Appearance : No abnormality Inductance change : Within $\pm 10\%$ Q change : Within $\pm 30\%$ (LHLP : only $\Delta L/L$)
FBA/FBR	
FL05□ Type	Refer to individual specification
FL06BT Type	Appearance : No abnormality Impedance change : Within $\pm 20\%$
[Test Method and Remarks]	
LHL□□□	: Temperature : $105\pm 3^\circ\text{C}$ Duration : 1000 ± 24 hrs Recovery : 1 to 2hrs of recovery under the standard condition after the removal from the test chamber.
FL	: Temperature : $85\pm 3^\circ\text{C}$ Duration : 500 (+12, -0) hrs Recovery : 1 to 2hrs of recovery under the standard condition after the removal from the test chamber.

* This catalog contains the typical specification only due to the limitation of space. When you consider purchase of our products, please check our specification.
For details of each product (characteristics graph, reliability information, precautions for use, and so on), see our Web site (<http://www.ty-top.com/>) or CD catalogs.

PRECAUTIONS

CAL Type, LH Type, FB Type, FL Type, LA Type

1. Circuit Design	
Precautions	<ul style="list-style-type: none"> ◆Operating environment 1. The products described in this specification are intended for use in general electronic equipment, (office supply equipment, telecommunications systems, measuring equipment, and household equipment). They are not intended for use in mission-critical equipment or systems requiring special quality and high reliability (traffic systems, safety equipment, aerospace systems, nuclear control systems and medical equipment including life-support systems,) where product failure might result in loss of life, injury or damage. For such uses, contact TAIYO YUDEN Sales Department in advance.
2. PCB Design	
Precautions	<ul style="list-style-type: none"> ◆Design 1. Please design insertion pitches of a base in the pitches that fitted a terminal interval.
Technical considerations	<ul style="list-style-type: none"> ◆Design 1. When Inductors are mounted onto a PC board, hole dimensions on the board should match the lead pitch of the component, if not, it will cause breakage of the terminals or cracking of terminal roots covered with resin as excess stress travels through the terminal legs.
3. Considerations for automatic placement	
Precautions	<ul style="list-style-type: none"> ◆Adjustment of mounting machine 1. Excessive impact load should not be imposed on the products when mounting onto the PC boards. 2. Mounting and soldering conditions should be checked beforehand.
Technical considerations	<ul style="list-style-type: none"> ◆Adjustment of mounting machine 1. When installing products, care should be taken not to apply distortion stress as it may deform the products.
4. Soldering	
Precautions	<ul style="list-style-type: none"> ◆Wave soldering 1. Please refer to the specifications in the catalog for a wave soldering. 2. Do not immerse the entire Inductors in the flux during the soldering operation. ◆Lead free soldering 1. When using products with lead free soldering, we request to use them after confirming of adhesion, temperature of resistance to soldering heat, soldering etc sufficiently. Recommended conditions for using a soldering iron: <ul style="list-style-type: none"> ·Put the soldering iron on the land-pattern. ·Soldering iron's temperature - Below 350°C ·Duration - 3 seconds or less ·The soldering iron should not directly touch the inductor. ◆Reflow soldering 1. As for reflow soldering, please contact our sales staff.
Technical considerations	<ul style="list-style-type: none"> ◆Lead free soldering 1. If products are used beyond the range of the recommended conditions, heat stresses may deform the products, and consequently degrade the reliability of the products.
5. Cleaning	
Precautions	<ul style="list-style-type: none"> ◆Cleaning conditions 1. CAL type, LH type, LA Type Please do not do cleaning by a supersonic wave.
Technical considerations	<ul style="list-style-type: none"> ◆Cleaning conditions 1. CAL type, LH type, LA Type If washing by supersonic waves, supersonic waves may deform products.
6. Handling	
Precautions	<ul style="list-style-type: none"> ◆Handling 1. Keep the inductors away from all magnets and magnetic objects. ◆Mechanical considerations 1. Please do not give the inductors any excessive mechanical shocks. 2. LH type If inductors are dropped onto the floor or a hard surface they should not be used. ◆Packing 1. Please do not give the inductors any excessive mechanical shocks. In loading, please pay attention to handling indication mentioned in a packing box (a loading direction / number of maximum loading / fragile item).
Technical considerations	<ul style="list-style-type: none"> ◆Handling 1. There is a case that a characteristic varies with magnetic influence. ◆Mechanical considerations 1. There is a case to be damaged by a mechanical shock. 2. LH type There is a case to be broken by a fall. ◆Packing 1. There is a case that a lead route turns by a fall or an excessive shock.
7. Storage conditions	
Precautions	<ul style="list-style-type: none"> ◆Storage 1. To maintain the solderability of terminal electrodes and to keep the packing material in good condition, temperature and humidity in the storage area should be controlled. Recommended conditions <ul style="list-style-type: none"> ·Ambient temperature 0~40°C ·Humidity Below 70% RH The ambient temperature must be kept below 30°C. Even under ideal storage conditions, solderability of products electrodes may decrease as time passes. For this reason, inductors should be used within one year from the time of delivery. In case of storage over 6 months, solderability shall be checked before actual usage.
Technical considerations	<ul style="list-style-type: none"> ◆Storage 1. Under a high temperature and humidity environment, problems such as reduced solderability caused by oxidation of terminal electrodes and deterioration of taping/packaging materials may take place.

* This catalog contains the typical specification only due to the limitation of space. When you consider purchase of our products, please check our specification. For details of each product (characteristics graph, reliability information, precautions for use, and so on), see our Web site (<http://www.ty-top.com/>) or CD catalogs.