

Please read this notice before using the ELNA products.

REMINDERS

Product Information in this Catalog

Product information in this catalog is as of December 2022. All of the contents specified herein and production status of the products listed in this catalog are subject to change without notice due to technical improvement of our products, etc. Therefore, please check for the latest information carefully before practical application or use of our products.

Please note that ELNA shall not be in any way responsible for any damages and defects in products or equipment incorporating our products, which are caused under the conditions other than those specified in this catalog or individual product specification sheets.

Approval of Product Specifications

Please contact ELNA for further details of product specifications as the individual product specification sheets are available. When using our products, please be sure to approve our product specifications or make a written agreement on the product specification with ELNA in advance.

Pre-Evaluation in the Actual Equipment and Conditions

Please conduct validation and verification of our products in actual conditions of mounting and operating environment before using our products.

Limited Application

1. Equipment Intended for Use

The products listed in this catalog are intended for general-purpose and standard use in general electronic equipment (e.g., AV equipment, OA equipment, home electric appliances, office equipment, information and communication equipment including, without limitation, mobile phone, and PC) and other equipment specified in this catalog or the individual product specification sheets.

ELNA has the line-up of the products intended for use in automotive electronic equipment, telecommunications infrastructure and industrial equipment, or medical devices classified as GHTF Classes A to C (Japan Classes I to III). Therefore, when using our products for these equipment, please check available applications specified in this catalog or the individual product specification sheets and use the corresponding products.

2. Equipment Requiring Inquiry

Please be sure to contact ELNA for further information before using the products listed in this catalog for the following equipment (excluding intended equipment as specified in this catalog or the individual product specification sheets) which may cause loss of human life, bodily injury, serious property damage and/or serious public impact due to a failure or defect of the products and/or malfunction attributed thereto.

- (1) Transportation equipment (automotive powertrain control system, train control system, and ship control system, etc.)
- (2) Traffic signal equipment
- (3) Disaster prevention equipment, crime prevention equipment
- (4) Medical devices classified as GHTF Class C (Japan Class III)
- (5) Highly public information network equipment, data-processing equipment (telephone exchange, and base station, etc.)
- (6) Any other equipment requiring high levels of quality and/or reliability equal to the equipment listed above

3. Equipment Prohibited for Use

Please do not incorporate our products into the following equipment requiring extremely high levels of safety and/or reliability.

- (1) Aerospace equipment (artificial satellite, rocket, etc.)
- (2) Aviation equipment ^{*1}
- (3) Medical devices classified as GHTF Class D (Japan Class IV), implantable medical devices ^{*2}
- (4) Power generation control equipment (nuclear power, hydroelectric power, thermal power plant control system, etc.)
- (5) Undersea equipment (submarine repeating equipment, underwater work equipment, etc.)
- (6) Military equipment
- (7) Any other equipment requiring extremely high levels of safety and/or reliability equal to the equipment listed above

*Notes:

1. There is a possibility that our products can be used only for aviation equipment that does not directly affect the safe operation of aircraft (e.g., in-flight entertainment, cabin light, electric seat, cooking equipment) if such use meets requirements specified separately by ELNA. Please be sure to contact ELNA for further information before using our products for such aviation equipment.
2. Implantable medical devices contain not only internal unit which is implanted in a body, but also external unit which is connected to the internal unit.

4. Limitation of Liability

Please note that unless you obtain prior written consent of ELNA, ELNA shall not be in any way responsible for any damages incurred by you or third parties arising from use of the products listed in this catalog for any equipment that is not intended for use by ELNA, or any equipment requiring inquiry to ELNA or prohibited for use by ELNA as described above.

Safety Design

When using our products for high safety and/or reliability-required equipment or circuits, please fully perform safety and/or reliability evaluation. In addition, please install (i) systems equipped with a protection circuit and a protection device and/or (ii) systems equipped with a redundant circuit or other system to prevent an unsafe status in the event of a single fault for a failsafe design to ensure safety.

Intellectual Property Rights

Information contained in this catalog is intended to convey examples of typical performances and/or applications of our products and is not intended to make any warranty with respect to the intellectual property rights or any other related rights of ELNA or any third parties nor grant any license under such rights.

Limited Warranty

Please note that the scope of warranty for our products is limited to the delivered our products themselves and ELNA shall not be in any way responsible for any damages resulting from a failure or defect in our products. Notwithstanding the foregoing, if there is a written agreement (e.g., supply and purchase agreement, quality assurance agreement) signed by ELNA and your company, ELNA will warrant our products in accordance with such agreement.

ELNA's Official Sales Channel

The contents of this catalog are applicable to our products which are purchased from our sales offices or authorized distributors (hereinafter "ELNA's official sales channel"). Please note that the contents of this catalog are not applicable to our products purchased from any seller other than ELNA's official sales channel.

Caution for Export

Some of our products listed in this catalog may require specific procedures for export according to "U.S. Export Administration Regulations", "Foreign Exchange and Foreign Trade Control Law" of Japan, and other applicable regulations. Should you have any questions on this matter, please contact our sales staff.

Equipment intended for use and product categories

Application	Product Group	
	Equipment ¹	Category (Part Number Code ²)
Automotive	Automotive Electronic Equipment (POWERTRAIN, SAFETY)	A
	Automotive Electronic Equipment (BODY & CHASSIS, INFOTAINMENT)	C
Medical	Medical Devices classed as GHTF Class C (Japan Class III)	M
	Medical Devices classed as GHTF Classes A or B (Japan Classes I or II)	L
Consumer	General Electronic Equipment	S

*Notes : 1. Based on the general specifications required for electronic components for such equipment, which are recognized by ELNA, the use of each product group for the equipment is recommended. Please be sure to contact ELNA before using our products for equipment other than those covered by the product group.
 2. On each of our part number, the 2nd code from the left is a code indicating the "Category" as shown in the above table. For details, please check the explanatory materials regarding the part numbering system of each of our products.

Automotive Application Guide

We classify automotive electronic equipment into the following four purpose of use and set usable product purpose of use for each of our products. Therefore, we have the corresponding product category code (the part number code of 2nd digit from the left side is "A" or "C").

When using our products for automotive electronic equipment, please be sure to check such application categories and use the corresponding product series accordingly. Should you have any questions on this matter, please contact us.

Product category (Part Number Code of 2nd digit from the Left Side)	Purpose of use	Automotive Electronic Equipment (Typical Example)
A	POWERTRAIN	<ul style="list-style-type: none"> • Engine ECU (Electronically Controlled Fuel Injector) • Cruise Control Unit • 4WS (4 Wheel Steering) • Transmission • Power Steering • HEV/PHV/EV Core Control (Battery, Inverter, DC-DC) • Automotive Locator (Car location information providing device), etc.
	SAFETY	<ul style="list-style-type: none"> • ABS (Anti-Lock Brake System) • ESC (Electronic Stability Control) • Airbag • ADAS (Equipment that directly controls running, turning and stopping), etc.
C	BODY & CHASSIS	<ul style="list-style-type: none"> • Wiper • Automatic Door • Power Window • Keyless Entry System • Electric Door Mirror • Automobile Digital Mirror • Interior Lighting • Automobile Air Conditioning System • TPMS (Tire Pressure Monitoring System) • Anti-Theft Device (Immobilizer), etc.
	INFO-TAINMENT	<ul style="list-style-type: none"> • Car Infotainment System • ITS/Telematics System • Instrument Cluster • ADAS (Sensor, Equipment that is not interlocked with safety equipment or powertrain) • Dashcam (genuine products for automotive manufacturer), etc.

NOTE : Design, Specifications are subject to change without notice.
 It is recommended that you shall obtain technical specifications from ELNA to ensure that the component is suitable for your use.

Code in front of series have been extracted from product code, which describes the segment of products, such as type and features.

- Low ESR and high ripple current are realized.
- HTQ is resist to vibration. (30G guaranteed)
- Equivalent to conductive polymer type Aluminum Electrolytic Capacitor.
(There are little characteristics change by temperature and frequency)
- Guaranteed 150° C, 1000 hours.
- Environmental : GREEN CAP™ , RoHS compliance.



Marking color : Blue print

Specifications

Item	Performance												
Category temperature range (°C)	-55 to +150												
Tolerance at rated capacitance (%)	±20 (20°C, 120Hz)												
Leakage current (µA) (max.)	0.01CV or 3 whichever is larger (after 2 minutes) C : Rated capacitance (µF) ; V : Rated voltage (V) (20°C)												
Tangent of loss angle (tan δ)	<table border="1"> <thead> <tr> <th>Rated voltage (V)</th> <th>16</th> <th>25</th> <th>35</th> <th>50</th> <th>63</th> </tr> </thead> <tbody> <tr> <td>tan δ (max.)</td> <td>0.16</td> <td>0.14</td> <td>0.12</td> <td>0.10</td> <td>0.08</td> </tr> </tbody> </table> (20°C, 120Hz)	Rated voltage (V)	16	25	35	50	63	tan δ (max.)	0.16	0.14	0.12	0.10	0.08
Rated voltage (V)	16	25	35	50	63								
tan δ (max.)	0.16	0.14	0.12	0.10	0.08								
Characteristics at high and low temperature	<table border="1"> <thead> <tr> <th>Impedance ratio (max.)</th> <th>Z-25°C/Z+20°C</th> <th>1.5</th> </tr> </thead> <tbody> <tr> <td></td> <th>Z-55°C/Z+20°C</th> <td>2.0</td> </tr> </tbody> </table> (100kHz)	Impedance ratio (max.)	Z-25°C/Z+20°C	1.5		Z-55°C/Z+20°C	2.0						
Impedance ratio (max.)	Z-25°C/Z+20°C	1.5											
	Z-55°C/Z+20°C	2.0											
Endurance (150°C) (Applied ripple current)	<table border="1"> <thead> <tr> <th>Test time</th> <th>1000 hours</th> </tr> </thead> <tbody> <tr> <td>Leakage current</td> <td>The initial specified value or less</td> </tr> <tr> <td>Percentage of capacitance change</td> <td>Within ±30% of initial value</td> </tr> <tr> <td>Tangent of the loss angle</td> <td>200% or less of the initial specified value</td> </tr> <tr> <td>ESR change</td> <td>200% or less of the initial specified value</td> </tr> </tbody> </table>	Test time	1000 hours	Leakage current	The initial specified value or less	Percentage of capacitance change	Within ±30% of initial value	Tangent of the loss angle	200% or less of the initial specified value	ESR change	200% or less of the initial specified value		
Test time	1000 hours												
Leakage current	The initial specified value or less												
Percentage of capacitance change	Within ±30% of initial value												
Tangent of the loss angle	200% or less of the initial specified value												
ESR change	200% or less of the initial specified value												
Shelf life (150°C)	Test time : 1000hours ; other items are same as the endurance. Voltage application treatment : According to JIS C5101-4 4.1.												

Outline Drawing

Unit : mm

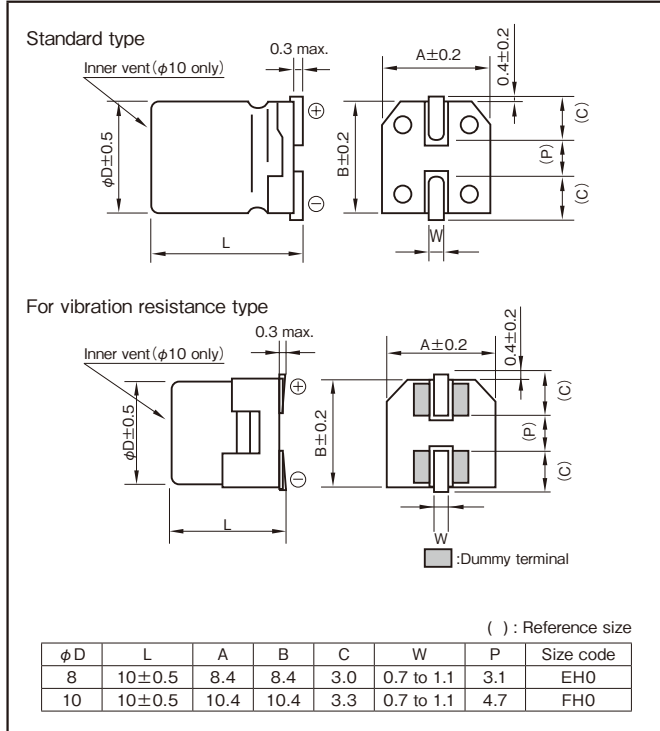

Refer to individual page.
(Soldering conditions, Land pattern size, The taping specifications)

Coefficient of Frequency for Rated Ripple Current

Frequency (Hz)	120	1k	10k	100k or more
Rated voltage (V)	0.10	0.30	0.60	1
16 to 63				

Product code system (*For general product)

φ8 (example : 16V270µF, Standard type)

RS*	HVQ	271	M	1E	EHO	002	
Category code	Series code	capacitance code	Cap tol. code	Voltage code	Size code	Taping and packing code	Additional code

φ10 (example : 16V470µF, Standard type)

RS*	HVQ	471	M	1E	FHO	002	X
Category code	Series code	capacitance code	Cap tol. code	Voltage code	Size code	Taping and packing code	Additional code

- For vibration resistance type should change Series code "HVQ" into "HTQ".
- For details, refer to the various "Product Code System" pages.

Code in front of series have been extracted from product code, which describes the segment of products, such as type and features.

Standard Ratings

Rated voltage (V) Rated capacitance (μF)	Item	16 (1L)			25 (1T)			35 (1G)			50 (1U)		
		Case φD×L (mm)	ESR (mΩ max.)	Rated ripple current (mA _{RMS})	Case φD×L (mm)	ESR (mΩ max.)	Rated ripple current (mA _{RMS})	Case φD×L (mm)	ESR (mΩ max.)	Rated ripple current (mA _{RMS})	Case φD×L (mm)	ESR (mΩ max.)	Rated ripple current (mA _{RMS})
68		—	—	—	—	—	—	—	—	—	8×10	30	660
100		—	—	—	—	—	—	—	—	—	10×10	28	800
150		—	—	—	—	—	—	8×10	22	710	—	—	—
220		—	—	—	8×10	22	740	—	—	—	—	—	—
270		8×10	20	740	—	—	—	10×10	20	830	—	—	—
330		—	—	—	10×10	20	850	—	—	—	—	—	—
470		10×10	18	850	—	—	—	—	—	—	—	—	—

Rated voltage (V) Rated capacitance (μF)	Item	63 (4E)		
		Case φD×L (mm)	ESR (mΩ max.)	Rated ripple current (mA _{RMS})
33		8×10	30	610
56		10×10	28	710

(Note) Rated ripple current : 150°C , 100kHz ; ESR : 20°C , 100kHz